

MIKRO MASTER® 300; MODEL 4322 CENTRAL SANITIZE DISPENSER

Product Description

The Ecolab Model 4322 is a proportioning system which provides highly accurate dispensing over a wide range of flow rates and concentrations.

Benefits

- Dependable dispensing over a wide range of concentrations and flow rates-prevents product overuse
- Compact size minimizes required wall space
- Uses available plant water; typically does not require additional pressure boosting pumps
- Central system minimizes worker handling of concentrated chemicals
- Consistent solution concentration eliminates potential for over concentration and increases worker safety
- Preassembled for easy installation
- Draws sanitation or lubricant product directly out of shipping container
- Simple and reliable design enables minimal, easy maintenance
- Easy calibration and adjustment assures accurate concentrations
- Backflow preventer included for water source protection
- Includes mixing changer for uniform dilution of sanitizer

→ 120VAC.

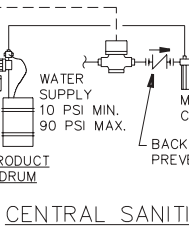

CENTRAL SANITIZ

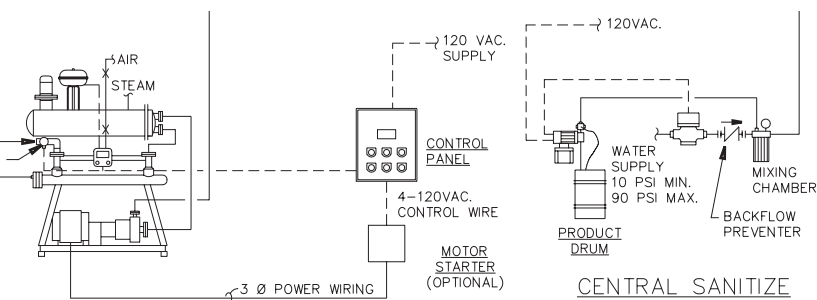

CENTRAL SANITIZ

ECOLAB®